



Wireless Thermo Recorder

RTR-501 / 502 / 503 / 507

User's Manual

RTR-501 With Internal Temperature Sensor	RTR-502 With External Temperature Sensor TR-5106 (Included)	RTR-503 With External Temperature-Humidity Sensor TR-3310 (Included)	RTR-507 With High Precision Temperature-Humidity Sensor HHB-3101 (Included)
--	--	---	--

Common Accessories:

- Lithium Battery LS14250
- Strap
- User's Manual (Warranty Included)

T&D Corporation

© Copyright T&D Corporation. All rights reserved.
 2016.11. 16504590040 (7th Edition)
 Printed on recycled paper.

What is a Wireless Thermo Recorder?

These products are data loggers designed to measure and record temperature and humidity with built-in wireless communication capability. No longer it is necessary to manually gather the data loggers. Rather via our special radio communication function, data download, settings, analysis and the saving of data can all be done via a wireless Base Unit connected to your PC.

RTR-501, RTR-502, RTR-503, and RTR-507 are Remote Units. They require Base Units to carry out wireless communication. For details about available operations via wireless communication or how to make recording settings, see the Introductory Manual included with the Base Unit or see the application's Help. Please set up the Base Unit first before the Remote Unit.

Part Names

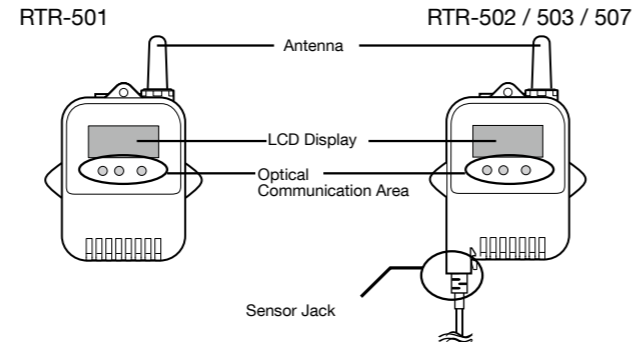

Connecting the Sensors

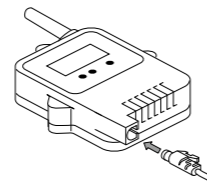

Make sure that the sensor is completely inserted until you hear a "click" sound.

Getting Remote Units Ready

Install the Batteries

When a battery is installed, the measurement will start at the factory default settings or the previously set ones.

Factory Default Settings

Recording Mode: Endless
 Recording Interval: 10 minutes
 Recording Start Method: Immediate Start

- Remove the screws and open the cover.
- Insert the supplied battery with tube into the case as shown in the diagram below.
- Check the rubber packing for any cuts or scratches and close the cover as it was when opened.

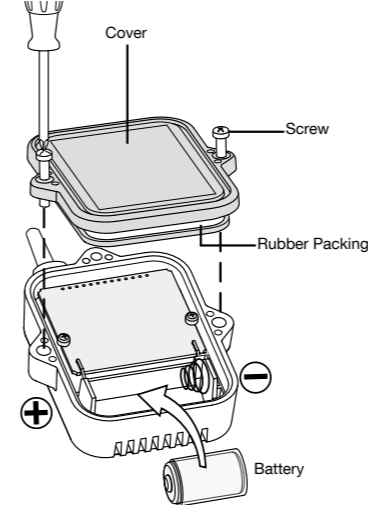

- Make sure to use the proper type and size screwdriver. (Phillips head #1 screwdriver is recommended.)
- If dirt or scratches are present on the rubber packing, water resistance will be reduced.
- Be sure to completely close the cover. Make sure not to over tighten the screws.
- Appropriate Tightening Torque: 20N · cm to 30N · cm (2Kgf · cm to 3Kgf · cm)

Battery Replacement

When a battery warning mark appears, try to replace the battery with a new one as soon as possible.

- When it is time for the battery to be replaced, a battery warning mark will appear.

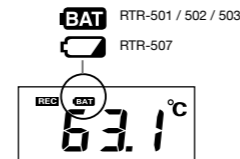

- If you do not change the battery and continue using the RTR-501, RTR-502, or RTR-503, the display will alternately flash [bAtt] and the current temperature. The RTR-507 will alternately flash [bAtt] and [----], and then stop the measurement. In this condition, recording will continue for both types of units.

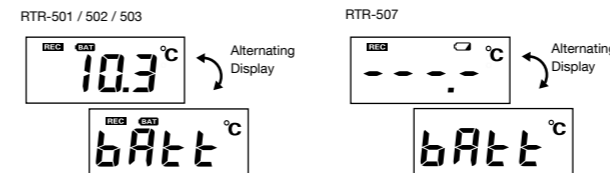

- At this point the downloading of data can no longer be done via wireless communication.
- Using optical communication to download data without changing the battery may cause the battery life to be shortened even more and result in the loss of recorded data during communication.

- If the battery is further left unchanged, the display will automatically shut off.

- All of the recorded data up until that point will be erased.

If the battery is replaced after the display turns off completely, [CHEC] will appear on the display after which recording will begin again using the previously set recording conditions.



Notes about Battery Installation

- If a new battery has been installed and recording does not immediately start, nothing appears in the display or any other such malfunction, please remove the battery, check to make sure plus and minus are correct and re-insert the battery.
- After inserting the battery for the first time, nothing may appear or occur for about 10 seconds; this is not a malfunction.
- If + (plus) and - (minus) are mistaken, or if the battery terminals + and - are shorted, the recorded data that is stored in the unit will be lost.
- When inserting a battery, make sure no water or foreign objects get inside the case.

About Lithium Batteries

- When using an LS14250 type lithium battery, even though a new battery has been inserted the [BAT] or [] indicator may remain on for a short time. This is due to a special characteristic of the battery. Note that the longer the battery has been in storage the longer the amount of time, from 10 minutes to about 1 hour, the battery warning mark will remain on. If during that time the Base Unit is used to get the current status of the Remote Unit, the remaining battery level will show that the battery level is low.
- Please store the LS14250 in a place that is 20°C or less.
- The estimated battery life of the Lithium Battery LS14250 is about ten months if recorded data is downloaded once a day or the monitoring occurs once every 10 minutes.
- When using lithium batteries other than LS14250 produced by SAFT, such as CR2, product specifications cannot be guaranteed nor can the performance of some functions, such as the battery warning function.
- Please avoid using the CR2 in the following situations:
 Using the unit in an environment below 0 °C or above 60 °C
 Exposing the CR2 to continuous vibration such as in transportation
- When using a CR2 lithium battery, the tube is not necessary.
- To maintain waterproof capacity, when changing batteries also change the rubber packing and the drying agent (silica gel). When using a CR2 lithium battery, please purchase the optional Maintenance Set (TR-00P1) to replace the rubber packing and silica gel.

About using in Low and High Temperature environments.

- Use in low temperature environments will result in a shortening of the battery life.
 -20°C : one half of life compared to normal temperatures
 -30°C : one third of life compared to normal temperatures
- Although under normal temperature environments the [bAtt], [BAT] or [] mark may not appear, it may still become impossible to carry out communication in low temperatures.
- Use in high temperature environments will also cause the battery life to be shortened. In environments of 60°C or higher, not only will battery life be shortened but the unit itself and its parts will deteriorate more rapidly. Please do not use in such environments for prolonged periods of time.
 60°C : one half of life compared to normal temperatures

Optical Communication (Communication with PC)

Optical Communication is carried out by placing a data logger (Remote Unit) face down on the Base Unit connected to the PC. Make sure to align the optical communication areas and slitted areas.

Operations that require Optical Communication

- To register as Remote Unit(s) and make necessary settings by using the software supplied with the Base Unit.
- To download recorded data directly from Remote Unit to PC.

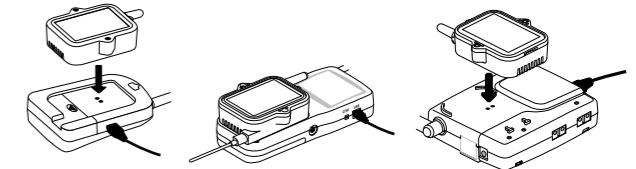

- If the battery level of the data logger is very low or optical communication is carried out in very hot or cold environments, communication may be broken or may not be possible.
- For details about Remote Unit registration and settings, see the application's Help

Reading the LCD Display

The LCD may become difficult to read when used in very hot or cold environments. This is a characteristic of the LCD panel and not a malfunction.

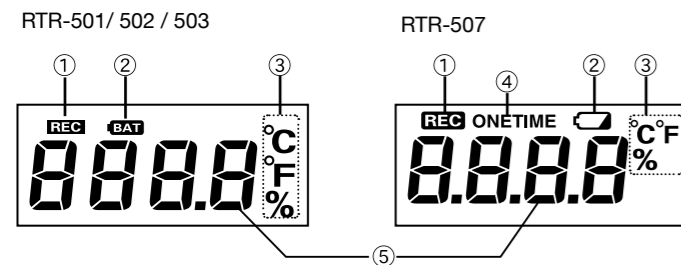

1 Recording Status [REC]

ON: Recording in progress
 BLINKING: Waiting for programmed start
 OFF: Recording stopped

2 Battery Warning Mark [BAT] / []

When it is time for the battery to be replaced, this mark will appear.

3 Units of Measurement

4 Recording Mode [ONETIME]

When the recording mode is set to One-Time Mode (Stop recording when capacity is full), this mark will appear.

5 Measurement and Message Display Area

Measurements or operational messages are shown here.

[Memory FULL]

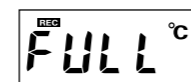

When the recording mode is set to "One Time" and the logging capacity becomes full, recording will stop and [FULL] will be displayed. This message will not appear in the "Endless" mode.

Logging Capacity

RTR-501 / 502 (Logging Capacity: 16,000 data readings)
 EX: Recording Interval of 30 seconds x data readings of 16,000 = 480,000 seconds (about 5 days and 13 hours)
 RTR-503 / 507 (Logging Capacity: 8,000 data sets)
 EX: Recording Interval of 30 seconds x data readings of 8,000 = 240,000 seconds (about 2 days and 18 hours)

Estimated time until [FULL] is displayed

Recording Interval	1 second	30 seconds	15 minutes	60 minutes
RTR-501 / 502	About 4 hours and 26 minutes	About 5 days and 13 hours	About 166 days and 16 hours	About 1 year and 10 months
RTR-503 / 507	About 2 hours and 13 minutes	About 2 days and 18 hours	About 83 days and 8 hours	About 11 months

[Check]

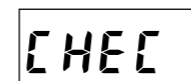

This will be displayed under the following conditions:
 The first time a battery was inserted after purchase
 When the battery is replaced after having been taken out for a long period

[Wireless Transmission]

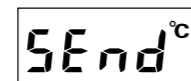

This will appear when data is being sent via wireless communication to the Base Unit.

[Measurement Range Exceeded] (for RTR-502)

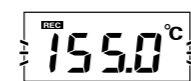

The current temperature display will blink when the temperature goes below -60 °C or above +155 °C.

[No Sensor] or other



This will appear when a sensor is not connected or the wire is broken. It will also appear on the RTR-507 when the measurement range is exceeded or the measurement is stopped due to low battery. Note that recording will continue to consume battery power.

Specifications

Unit type	RTR-501 / RTR-501L	RTR-502 / RTR-502L	RTR-503 / RTR-503L		RTR-507 / RTR-507L	
Measurement Channels	Temperature 1ch (Internal)	Temperature 1ch (External)	Temperature 1ch, Humidity 1ch (External)		1 Temperature Channel (External)	1 Humidity Channel (External)
Sensor	Thermistor	Thermistor	Thermistor	Polymer Resistance	Platinum Resistance	Electrostatic Capacitance
Measurement Units	°C, °F	°C, °F	°C, °F	%RH	°C, °F	%RH
Measurement Range	-40 to 80°C	-60 to 155°C	0 to 55 °C	10 to 95 %RH	-30 to 80 °C	0 to 99 %RH
Accuracy	Avg.±0.5 °C	Avg.±0.3 °C [-20 to 80 °C] Avg.±0.5 °C [-40 to -20 °C / 80 to 110 °C] Avg.±1.0 °C [-60 to -40 °C / 110 to 155 °C]	Avg.±0.3 °C	±5 %RH [at 25 °C, 50 %RH]	±0.3°C [at 0 to 50 °C] ±0.5°C [at all other temperatures]	±2.5 %RH [at 25 °C, 10 to 85 %RH] ±4.0 %RH [at 25 °C, 0 to 10 % or 85 to 99 %RH] For temperatures other than 25 °C and between 0 °C and 80°C, add ±0.1 %RH per degree difference from 25. Humidity Hysteresis: ±1.5 %RH or lower (*1)
Measurement Resolution	0.1°C	0.1°C	0.1°C	1 %RH	0.1 °C	0.1 %RH
Responsiveness	Thermal Time Constant: Approx. 15 min. Approx. 25 min. (L Type) Response Time (90%): Approx. 35 min. Approx. 47 min. (L Type)	Thermal Time Constant: Approx. 30 sec. (in air) Approx. 4 sec. (in agitated water) Response Time (90%): Approx. 80 sec. (in air) Approx. 7 sec. (in agitated water)	Response Time (90%): Approx. 7 min.		Response Time (90%): Approx. 7 min.	Response Time (90%): Approx. 20 sec.
Logging Capacity	16,000 readings		8,000 data sets (One data set consists of readings for multiple channels.)			
Recording Interval	Select from 15 choices: 1, 2, 5, 10, 15, 20, 30 sec. or 1, 2, 5, 10, 15, 20, 30, 60 min.					
Recording Mode (*2)	Endless (Overwrite oldest data when capacity is full) or One Time (Stop recording when capacity is full)					
Communication Interfaces	- Wireless Communication (Short Range Radio Communication) FCC Part15 Section247 / IC RSS-210 (Frequency Range: 902 to 928 MHz, RF Power: 7 mW) - Optical Communication (proprietary protocol)					
Wireless Transmission Range	Approx. 150 meters (500 ft) if direct and unobstructed					
Power	Lithium Battery: LS14250 x 1 L Type: Large Capacity Battery Adaptor Kit (RTR-500B1) (*3) External Power Adaptor Kit (RTR-500A2: sold separately) (*4)					
Battery Life (*5)	About 10 months L Type: About 4 years					
Dimensions	H 62 mm x W 47 mm x D 19 mm L type: H 62 mm x W 47 mm x D 46.5 mm (excluding protrusions and sensor) Antenna length: 24 mm					
Weight	Approx. 50 g L Type: approx. 65 g					
Operating Environment	-40 to 80°C (-30 to 80°C during wireless communication)			-40 to 80°C (-10 to 80°C during wireless communication) (*6)		
Waterproof Capacity	IP67: Immersion proof	IP64: Splash proof (rated for use in daily life) (*7)	IP64: Splash proof (rated for use in daily life) (*7) Note: Sensor is not water resistant.			
Compatible Base Units	RTR-500, RTR-500NW/500AW, RTR-500DC, RTR-500MBS-A					

- *1: When used in environments where temperature and humidity are over the values of 50°C 75%, 60°C 50%, 70°C 35%, and 80°C 25%, sensor hysteresis may fluctuate by values greater than ±1.5%RH. Under certain circumstances, it may take some time to return to normal measurement capability.
 *2: Only "Endless" is available when using RTR-500W for Windows or RTR-500MBS for Windows.
 *3: When using RTR-500B1 it is necessary to purchase Lithium Battery (LS26500). For details, contact your local authorized distributor.
 *4: RTR-500A2 should not be used with the RTR-501, as it will cause the RTR-501 to display a higher than actual temperature reading of up to 3°C.
 *5: Battery life varies depending upon the ambient temperature in which it is used, the recording interval, the frequency of communication, and the battery performance. All estimates are based on operations carried out with a new battery and are in no way a guarantee of actual battery life.
 *6: When wireless communication is performed in an environment below -10°C, measurement may fail or may not be accurate.
 *7: This is the waterproof capacity of the data logger with the sensor connected.
 The specifications listed above are subject to change without notice.

Cautions about using the Included Sensors

Temperature Sensor: TR-5106

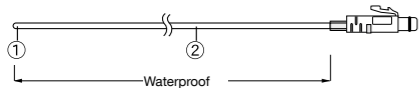

- Materials: ① Thermistor ② Fluoropolymer-coated Electrical Wire
- Do not bend or press the last 5 cm to the tip of the sensor, as this may damage it.
 - If the fluoropolymer-coated section of the sensor and/or the cable has a defect or tear, the waterproof capacity will be lost. Inspect it before operation.
 - Insert the sensor tip to at least 5 cm or more to obtain an accurate temperature measurement.
 - Only use the sensor within the sensor temperature durability range (-70 to 180°C).

Temperature-Humidity Sensor: TR-3310

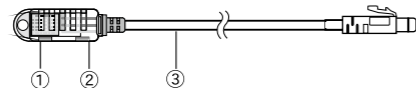

- Materials: ① Temp-Humidity Sensor ② Polypropylene Resin ③ Vinyl Chloride Coated Electrical Wire
- This sensor is not water resistant. Do not use it in places subject to condensation or dampness. If the sensor gets wet, immediately remove the sensor from the unit and wipe it with a clean cloth as soon as possible. Then allow the sensor to dry in normal room temperature before using it again.
 - Do not use the sensor in places subject to corrosive gases or organic solvents.
 - Do not expose the sensor to a strong impact. This may adversely affect measurement accuracy and cause damage or malfunction.
 - Continued use may cause a decrease in the sensor's accuracy and sensitivity even under normal operational conditions. Periodic calibration may be required.
 - When the sensor is not to be used for a long period of time, store it at normal temperature and humidity.

High Precision Temperature-Humidity Sensor: HHB-3101

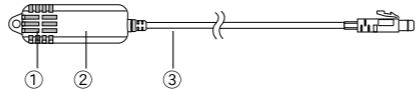

- Materials: ① Temp-Humidity Sensor ② Polycarbonate ③ Vinyl Chloride Coated Electrical Wire
- This sensor is not water resistant. Do not use it in places subject to condensation or dampness. If the sensor gets wet, immediately remove the sensor from the unit and wipe it with a clean cloth as soon as possible. Then allow the sensor to dry in normal room temperature before using it again.
 - Do not use the sensor in places subject to dust, corrosive gases or organic solvents.
 - Do not expose the sensor to a strong impact. It may adversely affect measurement accuracy and cause damage or malfunction.
 - Continued use may cause a decrease in the sensor's accuracy and sensitivity by about 1% per year even under normal operational conditions.
 - When used in environments where temperature and humidity are over the values of 50°C 75%, 60°C 50%, 70°C 35%, and 80°C 25%, sensor hysteresis may fluctuate by values greater than ±1.5%RH. Under certain circumstances, it may take some time to return to normal measurement capability.
 - When the sensor is not to be used for a long period of time, please store it at normal temperature and humidity.

Explanation of Symbols

<Warning Symbols>

	DANGER	These entries are actions that, if taken, may cause serious personal physical damage or death.
	CAUTION	These entries are actions that if taken may lead to physical injury or damage to persons or things.

<Picture Symbols>

	Denotes an important warning or caution.		Denotes a forbidden action.		Denotes an action that should be carried out.
--	--	--	-----------------------------	--	---

DANGER To Prevent Serious Accidents

- Do not disassemble, repair or modify the unit and accessories.
- Do not use the unit in any environment that is exposed to chemicals and harmful gases. Doing so may cause corrosion and/or other danger to the unit. Also, coming in contact with hazardous substances may cause bodily harm to the user or people nearby.
- If water or a foreign object enters the case, immediately remove batteries and stop using it.
- Do not insert or replace batteries with wet hands.
- This product has been designed for private and/or industrial use only. It should not be used in situations where strict safety precautions are necessary such as with medical equipment, or in systems directly or indirectly connected with human life or well-being.
- Do not drop or expose the unit to a strong impact.
- Do not cut or process the sensor cables. Also, do not twist, pull on or swing any of the cables.
- To prevent damage to the unit from static electricity, remove static electricity from your body by touching metal around you (such as a door knob and window frame) before touching the unit.
- Please be careful not to touch the unit during or after use in overly hot or cold environments. It may cause burns or frostbite.
- Place and store the unit and accessories out of the reach of children.
- Further, T&D is not responsible for any damage, malfunction or trouble, whether direct or indirect, caused by the use of our products.
- Do not use any power or sensors other than those specified by T&D Corporation.
- If the unit produces heat, emits smoke or a strange smell, or makes unusual noise, immediately remove the batteries and stop using it.

CAUTION Do not place or store in the following areas:

- Areas exposed to direct sunlight
- Areas subject to high temperatures such as near fire or heating equipment
- Areas exposed to static electricity
- Areas exposed to strong magnetic fields
- Areas exposed to dampness
- Areas subject to condensation or wet areas
- Areas exposed to excessive vibration
- Areas exposed to excessive smoke, dust or dirt.

CAUTION Other Precautions

- Use the unit in the specified operating environment. Do not use it for any purpose other than for which it was designed.
- Condensation may occur inside the case when a unit is moved from one environment to another where there is a great difference in temperature. Be careful to avoid condensation.
- Contact with oil may cause cracks to appear in the casing of the unit. When using this unit in environments where such oils are present, please insure that it is protected from contact through use of a polyethylene bag or other means.
- Do not insert any foreign objects into any of the units' jacks.
- The following may cause water or foreign objects to enter the unit:
 - Closing the case with dirt, dust, or hair on the rubber packing or between the unit and rubber packing
 - Scratches on the rubber packing
 - Involving a significant temperature change (especially from high to low) while the unit is wet
- If the unit gets dirty, wipe it with a clean cloth.
- Please note that this manual has been written based on the presupposition that details about set-up of any necessary equipment to enable network connection have already been taken care of by the user and that connection has been confirmed as workable. T&D Corporation shall not be responsible for any damages which a contractor, a user or a third party may suffer, whether direct or indirect, due to the inability to communicate or use communication devices.

CAUTION Installation Precautions for Wireless Communication Devices

- When installing wireless communication devices take special care in selecting locations so as to ensure proper communication. Note that even after a successful installation, due to changes in environmental conditions, communication errors may occur when restarting the system.
- As far as possible, try to keep wireless communication devices away from metals and set them up in high unobstructed positions.
- Please take note that in many instances, walls, floors, stairs, fences and desks will contain metals. In order to carry out communication between indoor and outdoor units, please locate indoor units near a window so that radio waves can be easily transmitted.
 - Please install the unit more than 30 cm away from walls or boards containing metal.
 - If the unit is placed in a metal container such as a freezer or refrigerator, the possible wireless communication range will be shortened. In most cases radio waves are transmitted via doors and door openings so place the unit as near to doors as possible.
 - As far as possible, keep the unit away from noise-emitting sources.
 - Equipment such as some industrial instruments, electronic devices or fluorescent lamps generate noise. Please place the unit more than 1 meter away from such devices.
 - Please place the unit more than 1 meter away from computers and other devices which emit noise.
 - Keep all wires as far away from wireless communication devices as possible. Please be careful about placing near any wiring or cables such as power supply cables, telephone wires or LAN cables.
 - Objects which contain lots of water, such as plants or soil, absorb radio waves. We highly recommend that such materials should not be placed between or near wireless communication units. When measuring temperature in a greenhouse it has been reported that as plants grew, communication errors also increased.
 - Do not place the unit directly on the ground.
 - Do not place units which are using the same communication frequency channel in the same area. If the same channel is used for multiple units not only will more communication errors occur, but battery life will also be shortened.
 - If there is a possibility that units with the same frequency channel will be in wireless communication at the same time, please make sure to make changes to the frequency channels so they are not the same.

Important Notices and Disclaimers

In order to properly use this product, please carefully read all documents that accompany the product before using. T&D Corporation accepts no responsibility for any malfunction of and/or trouble with this product or with your computer that is caused by the improper handling of this product and will deem such trouble or malfunction as falling outside the conditions for free repair outlined in the attached warranty.

- All rights of the attached documents belong to T&D Corporation. It is prohibited to use, duplicate and/or arrange a part or whole of the attached documents without the permission of T&D Corporation.
- Microsoft and Windows are registered trademarks of Microsoft Corporation in the United States and/or other countries.
- Windows Vista is either a registered trademark or trademark of Microsoft Corporation in the United States and/or other countries.
- All registered trademarks, company names, product names and logos mentioned herein or for products being used are the property or registered property of T&D Corporation or of their respective owners.
- Specifications, design and other contents outlined in the attached documents are subject to change without notice.
- Please follow the safety precautions outlined in the attached documents carefully. We cannot guarantee nor are we responsible for safety if this product is used in any manner other than was intended.
- On-screen messages in the attached documents may vary slightly from the actual messages.
- Please notify the shop where you purchased this product or T&D Corporation of any mistakes, errors or unclear explanations in the attached documents.
- T&D Corporation accepts no responsibility for any damage or loss of income caused by the use of our product.
- Accompanying documents cannot be reissued, so please keep them in a safe place.
- Please read the warranty and provisions for free repair carefully.

Compliance Information

FCC Statement

This device complies with Part 15 of the Federal Communications Commission (FCC) rules. Operation is subject to the following two conditions: (1) This device may not cause harmful interference, and (2) This device must accept any interference received, including interference that may cause undesired operation.

Caution:

Changes or modifications not expressly approved by the party responsible for compliance could void the user's authority to operate the equipment.

Note about Antenna Usage

This device has been designed to operate with the supplied antenna only. Use of any other antenna is strictly prohibited.

IC Statement

This device complies with RSS-210 of the Industry Canada (IC). Operation is subject to the following two conditions: (1) This device may not cause harmful interference; and (2) This device must accept any interference received, including interference that may cause undesired operation.

Ce dispositif est conforme à la norme RSS 210 d'Industrie Canada.

L'utilisation de ce dispositif est autorisée seulement aux conditions suivantes : (1) il ne doit pas produire de brouillage et (2) l'utilisateur du dispositif doit être prêt à accepter tout brouillage radioélectrique reçu, même si ce brouillage est susceptible de compromettre le fonctionnement du dispositif.

Wireless products cannot be used in countries other than where those products have been approved for use, according to that country's wireless regulations.

Important Notices

Wireless products cannot be used in countries other than where those products have been approved for use, according to that country's wireless regulations.

T&D Corporation shall in no manner whatsoever take responsibility for the usage of these products, nor be liable in any manner for legal consequences stemming from the usage of these wireless products in unapproved areas.

For product information or questions contact us at:

T&D Corporation

817-1 Shimadachi Matsumoto, Nagano 390-0852 JAPAN

Fax: +81-263-40-3152 E-mail: support@tandd.com

<http://www.tandd.com/>

We have opened an English Website for your convenience. Here you can find information about our company, news, products, upcoming events, software and Introductory Manual downloads, as well as, their support. Please stop by and see what we have to offer.